

	Nosaukums	Biezums	Skaits	Lāzeris	Locīšana	Apstrāde	Metināšana
<b>Montāžas kāja</b>							
1	UPN200	L2000	2				x
2	Grīda stabam	10	1	x			
3	Augšas plāksne	15	1	x			x
4	Gultņa māja	D100	1			x	x
5	TR30x6 vītņustienis	L2000	1				x
6	gultnis VKBA 3406		1				
7	Uzgrieznis vertikālajai vītnei	D55	1			x	x
8	M45x1,5 uzgrieznis 60170101		2				
9	sprostgredzens dīn472 m 80x2.5		1				
<b>Galvas turētājs</b>							
10	sagazuma regulēšana	20	1	x			x
11	enge 2 rev2	20	2	x		x	x
12	tapas atdure	10	2	x			
13	BULTSKRŪVE DIN 6921-12*25	L25	4				
14	BULTSKRŪVE DIN 933-12*40	L40	4				
15	UZGRIEZNIS DIN 934-12		4				
16	ISO 4762/DIN 912 gluds tērauds 12.9 SKR-CIL-IEKŠ-GKT-ISO4762-12.9-M20X60	L60	2				
17	Plakana paplāksne bez noapaļojuma DIN EN ISO 7089, karsti cinkots tērauds (HDG) PAPT-ISO7089-200HV-(HDG)-20		4				
18	tapa2		1			x	
19	tapa3		1			x	
20	Bultskrūve DIN 933-ISO 4017 M20x 250 ZN 8.8	L250	1				
21	DIN 934, ISO 4032, Uzgrieznis, M20, ZN, 8.0		1				
22	tapa		1			x	
23	Sprostgredzens DIN 471 50	D50	4				
24	regulēšanas plāksne	10	4	x		x	x
25	regulēšanas plāksnes atbalsts	5	8	x			x
26	auss pie ledenik	10	1	x			x
27	auss pie ledenik spogulis	10	1	x			x
28	salīta tapa riba	10	2	x			x
29	Trapecvītnes uzgrieznis TR30X6 melns L45 seškantis	L45	1				x
30	tapa4	D50	1			x	
31	salīkta tapa		1			x	x
<b>Galvas skelets</b>							
32	vertikāla pamatne 2	15	1	x		x	x
33	vertikāla pamatne	15	1	x		x	x
34	horizontāla pamatne 2	15	1	x		x	x
35	horizontāla pamatne	15	1	x		x	x
36	distanceris 5mm	5	2	x			x
37	vītnes atbalsts	5	2	x			x
38	distanceris un gultņa maja	10	2	x			x
39	rotācijas plāksne ap y	20	1	x			x
40	skrūves pamatne	15	1	x			x
41	skrūves pamatne 2	15	1	x			x
42	riba	15	2	x			x
43	riba 2	10	1	x			x
44	Trapecvītnes uzgrieznis TR30X6 apaļš		2				x
45	skrūve y sagazumam		1			x	
46	bultskrūve FOR-931-30X100	L100	1				
47	uzgrieznis dīn936 M30		1				
<b>Galvas apkare</b>							
48	Trapecvītne TR30x6 700mm	700	4				x
49	Trapecvītnes uzgrieznis TR30X6 melns L45 seškantis		4				x
50	piespiedēja detaļa1		4	x	x		x
51	piespiedēja detaļa2		2	x			x
52	piespiedēja detaļa3		4	x			x
53	vītnes auss		4	x			x
54	Tapa ar sprostū, Cat. 3, D=151 mm	ktu-uzkare	2				
55	PA vadīkla	20	4			x	
56	Skrūve ar gremdgalvu DIN 7991 10.9 M8x35 melna	L35	20				
57	gultņa vacins 2mm	2	4	x			
58	Skrūve ar pusapaļu galvu ISO 7380 10.9 M8x20 melna	L20	4				
59	Uzgrieznis DIN985 FZB M8		4				
60	CINK. PĀGARINĀTS UZGRIEZNIS DIN6334 M16		2				
61	GULTNIS 6003NR NTN		2				
62	Trapecvītne TR20x6 509mm	509	2				
63	Tr20 uzgrieznis		2			x	x
64	Kalibrētais D10 15 mm	15mm	2				x
	Distanceris 10mm	10mm	4				
	videja riba piespiedējam	5mm	2	x			x
	Šķēltapa		2				

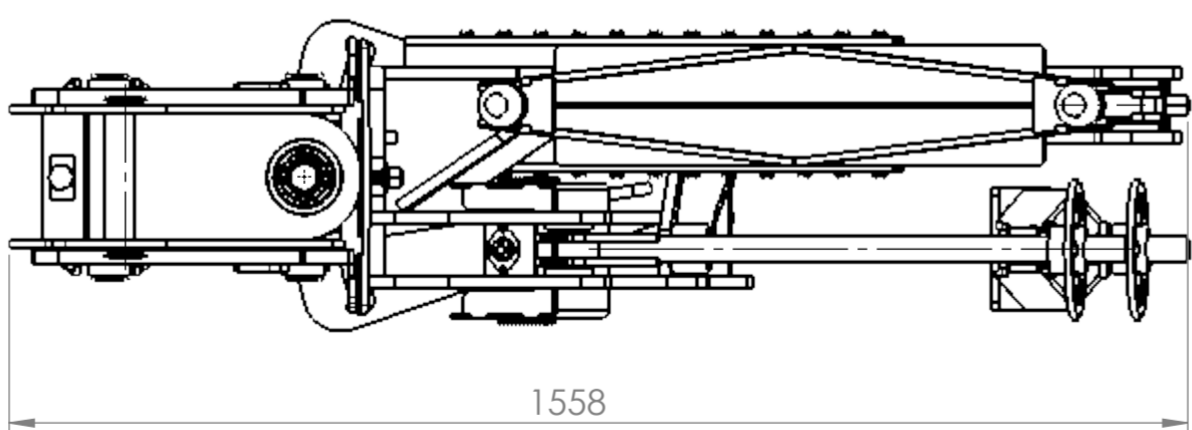
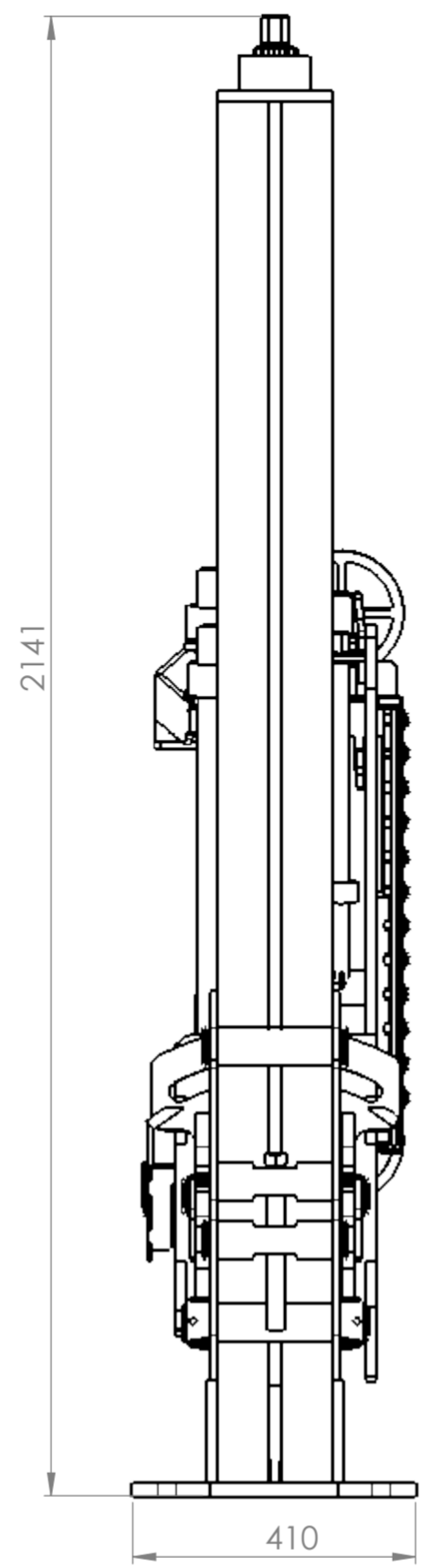
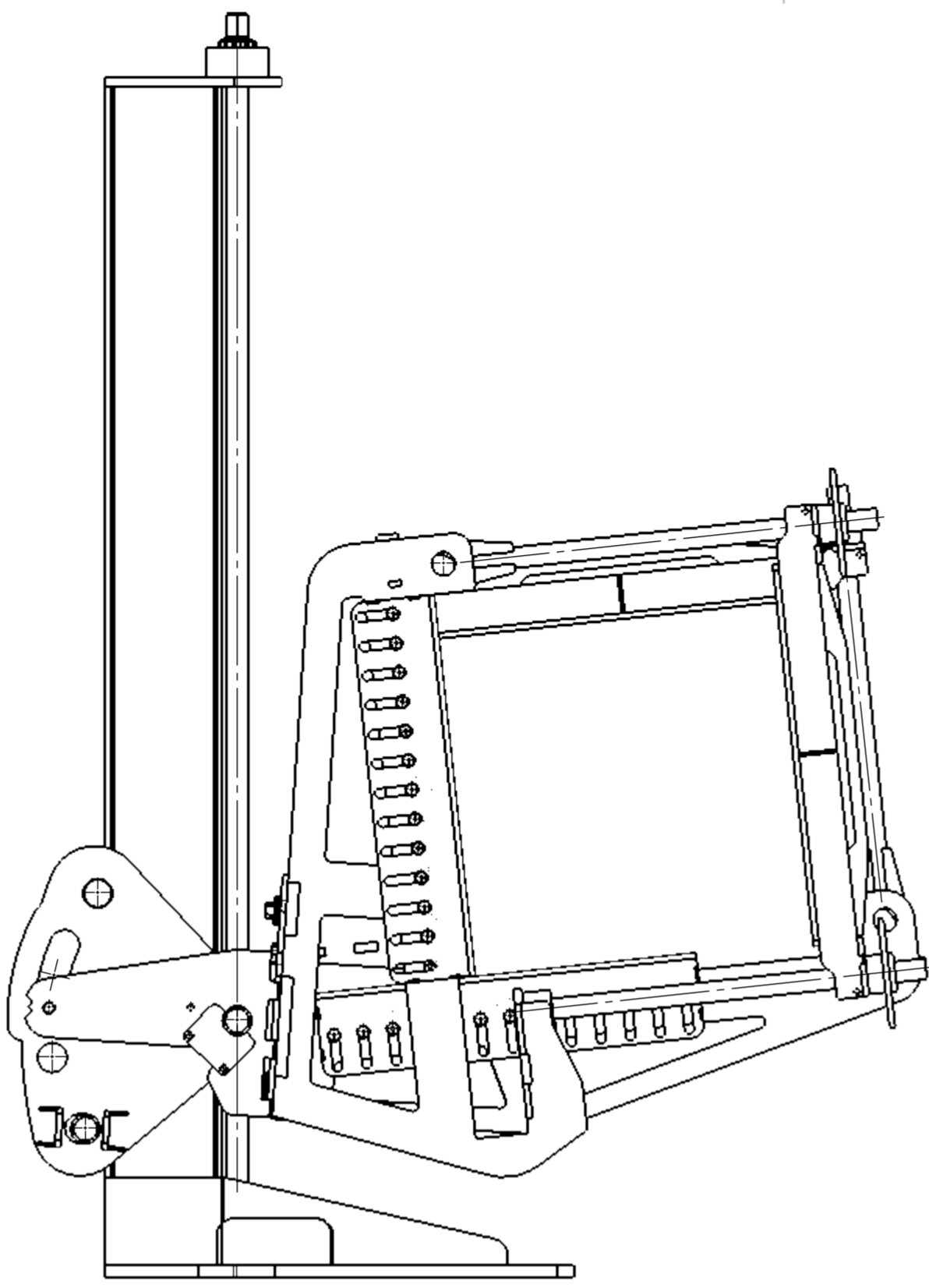

Presēšanas galva uz 102 cauruli							
65	Aptvere caurulei	4	2	x	x		x
66	Auss	10	2	x			x
67	bukse		52			x	
68	caurulis aizspiedējs	4	8	x		x	
69	gala plāksne	4	4	x			x
70	PA6 distanceris	10	2				
71	upn160 pamatne		2			x	
72	Skrūve ar gremdgalvu DIN 7991 10.9 M4x12 melna	L12	72				
73	ISO 7380-2, cinkots tērauds 010.9 M10x30	L30	52				
74	Caurule D102 7050FLEX0200	L700	2			x	
75	ventiļis caurulei		2			x	

470 kg

UNLESS OTHERWISE SPECIFIED: DIMENSIONS ARE IN MILLIMETERS SURFACE FINISH: TOLERANCES: LINEAR: ANGULAR:	FINISH:			DEBURR AND BREAK SHARP EDGES	DO NOT SCALE DRAWING		REVISION
	NAME	SIGNATURE	DATE		TITLE:		
DRAWN				DWG NO. <b>3D prese</b> A2			
CHK'D							
APP'VD							
MFG							
Q.A.				MATERIAL:	SCALE:1:20		
				WEIGHT:	SHEET 1 OF 1		